



## VOLUMETRIC VALVE

The Volumetric Valve is built with the highest quality materials and advanced technology providing our customers with consistent drink quality.

- Over 500,000 Lancer Volumetric Valves in the market
- Lancer Volumetric Valve is the only market proven valve in the industry (10 years)
- Consistent "Best in Class" performance
- Reduced service costs (no rebrixing)
- Lancer Volumetric Valves using volumetric metering give accurate ratio over life of valve
- Once set, no adjustment
- A Lancer valve designed for Coca-Cola to be the benchmark for other valves



Self-Serve



Portion Control



Crew-Serve



Push Button





# Volumetric Valve

## SPECIFICATIONS



Water Button

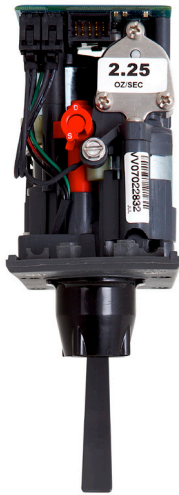

Bare Valve

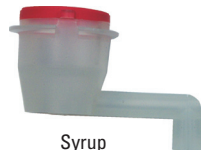

Syrup Separator Nozzle



Programmer



Flow Controls

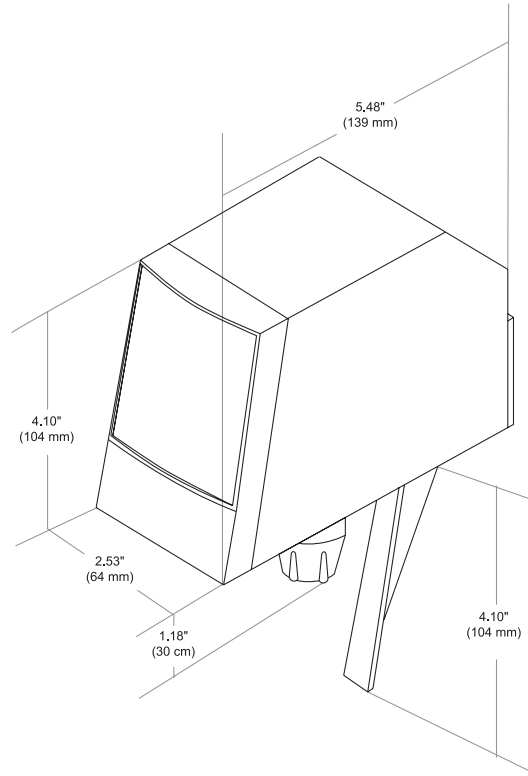

### PRESSURE REQUIREMENTS (FLOWING PRESSURE)

Water: 40 - 110 psig (2.8 - 7.7 bar)  
 Syrup (Sugar): 20 - 70 psig (1.4 - 4.9 bar)  
 Syrup (Diet/Light): 10 - 70 psig (0.7 - 4.9 bar)

### DRINK FLOW RATES

3.0 oz/sec (90 ml/sec)  
*(Grey flow washer assembly)*

2.3 oz/sec  
*(White flow washer assembly)*

1.5 oz/sec (45 ml/sec)  
*(Red flow washer assembly)*

### ELECTRICAL REQUIREMENTS

24 VAC, 50/60 Hz

### MOUNTING

Uses LEV® Mounting Block -  
 LEV mounting block has the same mounting  
 screw hole pattern as the following:  
 Dole SEV  
 Dole FFV  
 Cornelius SF-1  
 McCann Turbo Flo Jr.

**Warranty:** For warranty specifics by product,  
 contact your Lancer Sales Representatives.

Equipment design and/or specifications may change without notice.

CORPORATE OFFICE 6655 Lancer Blvd • San Antonio, TX 78219  
 210-310-7000 • 1-800-729-1500 • FAX 210-310-7250 • www.lancercorp.com

"Lancer" is the registered trademark of Lancer Corporation • © 2011 Lancer, all rights reserved.

VolValve\_SS 06/11